



Continuous Liner System CLS / CLCC

Containment-Level \leq OEB 5 ($<1\mu\text{g}/\text{m}^3$)

LUGAIA
Containment solutions



Continuous Liner System

Continuous Liner / Liner Carrier

The **Lugaia Continuous Liner Systems** prove themselves strongly when it comes to the safety of the staff and protection of your product. Axial folding enables film lengths of up to 80 meters. Fold height and foil length are depending on the film thickness.

On request, Lugaia also produces special CLS liner sizes from customer-specific foils.



The advantages of the Continuous Liner:

- High product and personal protection in the OEB 5 (<math><1\mu\text{g}/\text{m}^3</math>) Containment-Level
- Easy handling
- Customer customizable foil material
- Up to 80 meters per unit
- Less personal protection required
- Reduced or no cleaning of the environment
- Maximum film capacity in the smallest of spaces
- Different diameters and folding heights available
- Foil thickness of 50-150 μm
- High quality / manufactured in the ISO clean room

Continuous Liner as Primary or Secondary Packaging

Folding technique:

Thanks to a special axial fold made from tubular foil, the Continuous Liner allows packaging in different manufactured sizes. With this folding process, it is possible to fold a maximum foil length (up to 80 m) into the smallest space available. This decreases the frequency for needed changes of the Continuous Liner packaging which saves time and costs.

Custom film material:

Lugaia offers the opportunity for Continuous Liners to be manufactured from a customized packaging foil material. The Continuous Liner can be used for readily validated applications.

By default, depending on the application, the Continuous Liners are made of a pure or antistatic LPDE.

Clean room assembly:

The best tailored and quality guaranteed processes for our customers are available in 3 Continuous Liner clean room classes: ISO 5, ISO 7 and ISO 8.

High containment solution:

For sealing and separating, the Continuous Liner will be using the Lugaia patented SafeSeal Closure System. Whereby an OEB 5 (<math><1\mu\text{g}/\text{m}^3</math>) Containment-Level can be guaranteed.

The possible uses:

- Filling Stations
- Filling of API's (Active Pharmaceutical Ingredients) and toxic and highly reactive products
- Isolator and clean room application (Foil lock)
- Primary packaging
- Waste locks
- Material locks
- Sampling

Continuous Liner System

Scope of Delivery / Possible Applications

The Liner Carrier System is used wherever endless liner is attached to a plant or an isolator system which needs to be installed as a foil lock. The foil package is placed on the carrier tube that is sealed with an O-ring and also pressed off and secured with an O-ring clamping ring.

The connection of the Liner Carrier is individually adapted to the interface of the system, for example through TriClamp or flange connection.



Scope of Delivery:

- 1 Liner Carrier
- 2 Linerunit
- 3 O-ring and clamping ring
- 4 SafeSeal Premium Toolset
- 5 SafeSeal crimp
- 6 SafeSeal opener

Application examples



A CLS horizontal port

B CLS vertical product port



CLS wall installation

Continuous Liner System

CLS Standard Sizes

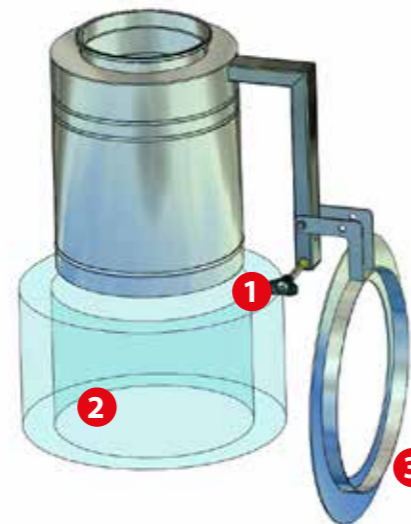
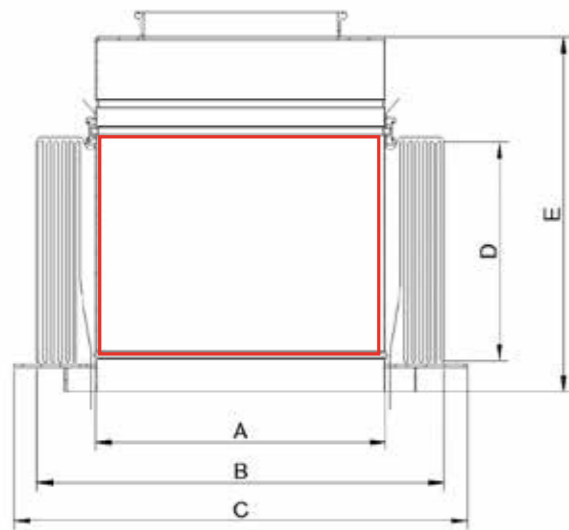

- 1 Ball-lock pin
- 2 CLS-Liner
- 3 Foldable retaining ring



Scan the QR code and watch directly the video

CLS Continuous Liner Types

Type	Foil width (mm)	B= Foil diameter (mm)	D= possible Liner heights (mm)	Foil lengths (m)	A= Tube diameter (mm)	C= Holder diameter (mm)	E= Liner Carrier construction height (mm)
CLS-300	300	190	150 / 300	5-20	115	240	Liner height + approx. 150 mm
CLS-400	400	250	150 / 300	5-20	170	300	
CLS-500	500	320	170 / 250 / 400	20-40	220	370	
CLS-600	600	380	170 / 250 / 400	20-50	300	430	
CLS-700	700	450	170 / 250 / 400	20-50	340	500	
CLS-800	800	500	170 / 250 / 400	20-50	370	550	
CLS-910	910	580	170 / 250 / 400	20-80	420	630	
CLS-970	970	620	170 / 250 / 400	20-80	450	670	
CLS-1100	1100	700	170 / 250 / 400	20-80	530	750	

Corresponding Liner Carrier Types

Continuous Liner System

Continuous Liner

Continuous Liner Carrier System from Lugaia – effective and popular

Clean room production ISO 5, ISO 7 and ISO 8

Quality is the top priority in the manufacturing process of our products. Our quality management system provides credentials for this with certifications according to ISO9001: 2015 and ISO15378: 2017 (primary packaging for pharmaceutical applications). In our class ISO 5, ISO 7 and ISO 8 clean rooms, we use cutting-edge technology for processing and welding of foils according to validated processes on qualified systems.



Equipping the CLS Continuous Liner Carrier



Fit the O-ring on the carrier tube



Put the foil on the package



Seal with clamping ring and close with SafeSeal Closure System

The Continuous Liner



Foil variants:

- PE with antistatic characteristics
- Pure PE for primary packaging
- PE with antistatic or conductive grid printing
- Barrier foils
- Custom foils

FDA, EP and USP approved

Continuous Liner System

CLCC Continuous Film Carrier

CLCC Continuous Liner Carrier (with RTP Beta)

Rapid transfer port systems for high containment



CLCC Continuous Liner Carrier

Scan the QR code and watch directly the video



Our Continuous Liner Carrier combined with the RTP Beta-System makes it possible for inward and outward transfers at RTP Alpha interfaces. The Continuous Liner Types CLS-300-910 can be combined with the RTP Beta-Ports 190-460.

The advantages of the CLCC Carrier:

- Light design through use of plastic
- Continuous Liners are easily assembled
- Custom design
- Tested RTP connection system

Continuous Liner System

CLCC Sizes and Scope of Delivery

The Standard Sizes

- When combined, the RTP Beta-Ports are arbitrary with our Continuous Liner Types CLS-300-910.
- Depending on the type of Continuous Liner, fold heights between 150-400 mm can be chosen.
- Design and dimension can be manufactured according to customer specifications.

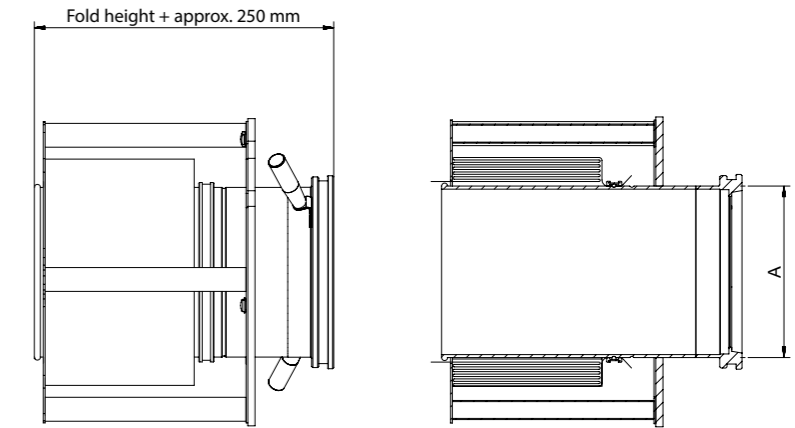

Type RTP Beta-Port (Measure A)	CLS Continuous Liner Types	CLS Continuous Liner Fold Heights
DPTE-190	CLS-300-910	150-400 mm
DPTE-270		
DPTE-350		
DPTE-460		

Equipping the CLCC Continuous Liner Carrier



Remove the retention basket



Fit the O-ring



Put on the Continuous Liner



Seal the Continuous Liner on the carrier tube



Mount the retaining basket



Close the Continuous Liner with SafeSeal

Continuous Liner Carriers form the interface between the outlet and the Continuous Liner Package and guarantee appropriate handling and protection. There are specific requirements for each application that we have taken into account when designing our standard Liner Carriers. This way we can achieve the highest possible occupational safety and ensure user-friendliness.



Scope of Delivery:

- 1 Liner Carrier
- 2 Liners
- 3 O-ring and clamping ring
- 4 SafeSeal Premium Toolset
- 5 SafeSeal crimp
- 6 SafeSeal openers



Lugaia AG
Containment Solutions

Industriezone Basper 31
3942 Raron, Switzerland
Telephone +41 (0) 27 948 45 55
Telefax +41 (0) 27 948 45 50
anfrage@lugaia.ch

Lugaia Deutschland GmbH
Containment Solutions

Westendstraße 2
85084 Reichertshofen, Germany
Telephone +49 (0) 8453 33 550-0
Telefax +49 (0) 8453 33 550-99
info@lugaia.de

Lugaia USA, LLC
Containment Solutions

Ponte Vedra Beach, Florida
Telephone +1 904 401 0003
info@lugaia.com

www.lugaia.com

Our product overview:

- CLS – Continuous Liner System
- Liner Carrier Systems
- SafeSeal Closure System
- SafePortBag
- TransferBag
- SafeFlex Isolators
- Individual special solutions

follow us on

