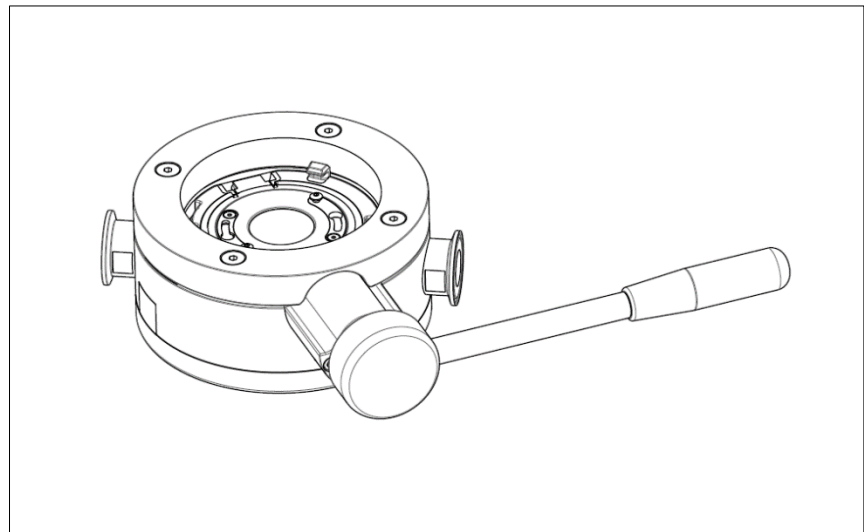

Technical Data

AVAX-AF
stainless steel
 Containment Split Butterfly Valve with active flange and suction port

Item No.
AVS 100-107.00

Multi-Use Containment interface for dust free transfer of solids.

Operation conditions

Operating pressure	Atmospheric conditions
Operating temperature	-20°C to +80 °C

Standard assemblies

Containment interface	Tri Clamp BS 4825-3 Nominal O.D. 4 inch / 101,6 mm
Operation	Manual execution fixed hand lever on the flange with stop for adjusting the valve disc
Suction port	Tri Clamp DN25 acc. to DIN 32676-A

Dimensions

Nominal diameter	DN100
Component assembly	199 mm x 121,7 mm (diameter x height)
Hand lever	292,5 mm
Weight	20 kg

Surface details

Surface roughness	Ra ≤ 0,8 µm (Product-contacted) Ra ≤ 1,6 µm (Non product-contacted)
Product-contacted surface	36248 mm ²

Material

Stainless steel production parts	1.4404 / 316L (Product-contacted) 1.4301 / 304 (Non product-contacted)
Sealings	EPDM
Bearings	PEEK

Certification / Datasheets

Material	Material specification
Cert.	FDA conformity (Product-contacted parts)

Compatibility / Accessories

Compatible systems	AVAX plastic, ACUBE, ACUBE-PRO, AVAX stainless steel, Adjustable frame for ACUBE
Accessories operation	AVAX Locking Tool, Lid, AVAX stainless steel wash adapter, Handle