



ARMYLOR®  
PTFE BELLOWS  
& COMPENSATORS



# CONTENT

MERSEN ANTICORROSION EQUIPMENT	p.2
RANGE OF BELLOWS & COMPENSATORS	p.3
REFERENCES	p.4
TECHNICAL SPECIFICATIONS	p.5-6
BELLOW FLANGES	p.7
COMPENSATOR FLANGES	p.8
STANDARD BELLOWS TYPE 207	p.9-10
REINFORCED BELLOWS TYPE 227	p.11-12
COMPENSATORS TYPE G283	p.13-14

# MERSEN ANTICORROSION EQUIPMENT

The Mersen AntiCorrosion Equipment activity is internationally recognized for its expertise in the design and manufacture of process equipment, manufactured from corrosion resistant materials (graphite, silicon carbide, tantalum, zirconium, PTFE). Mersen also has an in-depth knowledge of the process technologies requiring our AntiCorrosion Equipment and can provide offers from the basic equipment only, up to skid-mounted turn-key process packages.

ARMYLOR® includes a wide range of PTFE bellows and compensators offering an exceptional ability to resist corrosion at high temperature, ageing and especially alternate bending.

The performance of these products results from the intrinsic qualities of PTFE and the control of the production processes employed. ARMYLOR® is the ideal answer to the problem of transferring fluids in extreme conditions. MERSEN offers a wide range of equipment to the process industries, manufactured in various materials.

## INTERNATIONAL PRESENCE, SHORT DELIVERY TIMES

Based on its international network, MERSEN has set up a safety stock of semi-finished products in all its subsidiaries, providing short delivery times. The Mersen Pagny-sur-Moselle site is certified in accordance with ISO9001. All our bellows and compensators are manufactured in accordance with the European Directive relative to equipment operating under pressure : 2014/68/UE (ex 97/23/CE).

	HEAT EXCHANGERS	REACTORS, VESSELS AND COLUMNS	PIPING BELLOWS ACCESSORIES	PROCESS TECHNOLOGIES
GRAPHITE	BLOCKS, CUBIC AND TUBES		RUPTURE DISCS	
SILICON CARBIDE	BLOCKS AND TUBES			
TANTALUM	TUBES AND BAYONETS		TANTALUM SMALL PARTS	<b>FEEDSTOCK</b>
ZIRCONIUM				H <sub>2</sub> SO <sub>4</sub>
TITANIUM				Br <sub>2</sub>
NICKEL ALLOYS				HCl
PTFE			PIPING AND BELLOWS	Cl <sub>2</sub>
	<b>AFTER-SALES SERVICE</b>			FeCl <sub>3</sub>
				HBr
				Brine
				Flue Gas
				<b>PROCESS FUNCTIONS</b>
				Gas cleaning / Vent treatment
				Distillation / Desorption / Stripping
				Organic removal
				Absorption
				Production
				Burner
				Temp. Control
				Concentration
				Vaporizer
				Dilution
				Vacuum system
				Gas Drying
				Inorganic removal

# RANGE OF BELLOWS & COMPENSATORS

The ARMYLOR® bellows and compensators compensate for thermal expansion in pipelines.

They are commonly used to protect fragile equipment (graphite, glass-lined equipment, plastic, etc.) or to absorb vibrations of equipment (pumps, etc.). Additionally ARMYLOR® bellows can be used in extreme corrosive or high-temperature conditions.

MERSEN offers a comprehensive range of expansion joints in ARMYLOR®.

STANDARD BELLOWS	REINFORCED BELLOWS	COMPENSATORS
TYPE 207	TYPE 227	TYPE 283
		
<p>ARMYLOR® type 207 bellows, reinforced by stainless steel rings, which fulfill the requirements of most pressure applications.</p>	<p>ARMYLOR® type 227 bellows, reinforced by stainless steel rings and shells, which can withstand higher pressure, whilst keeping their flexibility.</p>	<p>ARMYLOR® type 283 compensators are externally reinforced by a stainless steel housing and allow operation at very high pressure.</p>

Operation in vacuum for types V207 and V227

# REFERENCES

Each ARMYLOR® item has a reference which allows it to be defined. This reference is composed of 13 alphanumeric characters (C1 to C13). In certain cases, the criteria can be identified by a dash (-) if it corresponds to the standard. The references of the dimensional tables are those of standard construction.

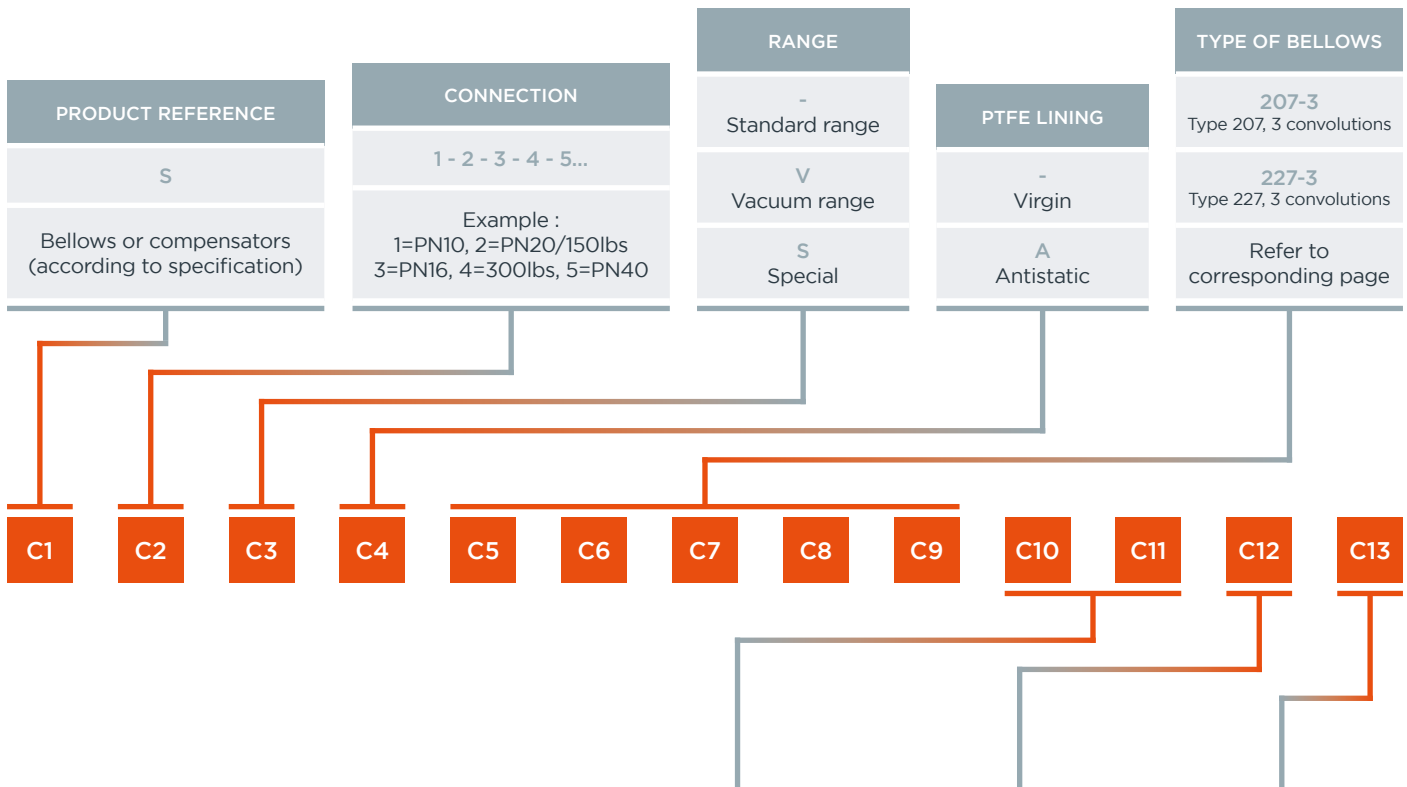

## Examples

Bellow, flange connection PN10, type 207, 5 convolutions DN200.  
**S1--207-5T**

Bellows, connection 150 lbs, vacuum range, Antistatic PTFE, type 227, 3 convolutions, DN300, stainless steel flanges.  
**S2VA227-3V--X**

## Examples of the reference in a table

REFERENCES					
C1	S	S	C6	0	2
C2	1	2	C7	7	7
C3	-	V	C8	-	-
C4	-	A	C9	5	3
C5	2	2	C10	T	V

DIAMETER	LOOSE FLANGES	STEEL PARTS
For each diameter, corresponds a letter. Refer to the table hereafter	- 0	- Standard
For bellows C11= --		R Low temperature Carbon steel
		X Stainless steel
		S Special

CODIFICATION REP	DIAMETER DN (MM)	CODIFICATION REP	DIAMETER DN (MM)
H	15	U	250
J	20	V	300
K	25	W	350
L	32	X	400
M	40	Y	450
N	50	Z	500
O	65	B	600
P	80		
Q	100		
R	125		
S	150		
T	200		

# TECHNICAL SPECIFICATIONS

## PTFE MEMBRANES

The membranes of ARMYLOR® bellows and compensators are manufactured by the paste extrusion of fine powder PTFE (polytetrafluorethylene) in accordance with standard ASTM D 4895. They are then molded under pressure and temperature, ensuring no damage to the material fibers. This technique offers excellent resistance to alternate bending (over 300,000 cycles) together with a very high resistance to permeation.

The PTFE used to produce the membranes complies with ASTM F 1545, the characteristics of which are indicated in the table below.

MERSEN also offers antistatic PTFE membranes.

	UNITS	
SPECIFIC DENSITY	g/cm <sup>3</sup>	2.14 - 2.19 ASTM D792
TENSILE STRENGTH	Mpa	210 mini
ELONGATION AT BREAK	%	250 mini

## STEEL COMPONENTS

The bellows are connected with carbon steel flanges P265G-H / EN 10 222 or equivalent. On request, flanges can be manufactured in stainless steel.

**Protection of steel components :** The flanges are protected with either zinc plating (standard product) or protected by a layer of zinc ethyl silicate primer, compatible with most of the final paint systems.

Special painting or other processes are available upon request.

SERIES	REINFORCEMENT RINGS	REINFORCEMENT SHELL	TIE ROD	REINFORCEMENT HOUSING
207	Stainless steel 304 L 1.4307		Classe 8-8 Galvanized	
204	Nickel Alloys C276 2.4819		Classe 8-8 Galvanized	
224	Nickel Alloys C276 2.4819	Monel 400 2.4360	Classe 8-8 Galvanized	
227	Stainless steel 304 L 1.4307	Stainless steel 304 L 1.4307	Classe 8-8 Galvanized	
283				Stainless steel 316 L 1.4404



## INSPECTION AND CONTROL, CERTIFICATES

All our products are inspected and controlled by our Quality Department in accordance with our ISO 9001 quality assurance system. Design and manufacturing control meet the requirement of the Pressure Equipment Directive PED 2014/68/UE (ex-97/23/CE ). Mersen can supply a Bureau Veritas certificate for marine offshore applications.

## DESIGN

Flanges with plain connect the standard bellows.

On request, the holes can be tapped.

The compensators are fitted with standard flanges conforming to the type of drilling requested (PN or ANSI).

The flanges have PN 10, PN 16, ANSI 150 lbs or ANSI 300 lbs drilling and other standards are available on request.

The maximum operating pressure of the bellows and compensators must be in accordance with the respective pressure/temperature resistance performance curves.

## INSTALLATION PROCEDURE

### Precautions

Do not remove the wooden plugs until the time of installation; once the plug is removed, great care must be taken to avoid damaging the PTFE.

### Cleaning

The sealing surfaces must be carefully cleaned before installation.

### Bolt tightening

The installation of ARMYLOR® bellows and compensators does not require any additional gasket, except when connecting to materials of a different nature or in the case of successive assembly and disassembly operations.

#### Bolt tightening

- Insert the washers
- Clean and grease the bolts
- Tighten the nuts manually
- Tighten each bolt with a torque wrench, respecting the tightening torques
- Tightening is carried out “crosswise”, as for any flange connection

The values of tightening torques are available in the assembly instructions delivered with the ARMYLOR® components. The tightening torques are at-cold values and must always be verified when the equipment is cold, after 24 hours of operation then periodically thereafter.

The tightening torque values indicated herein also apply to :

- Class 8.8 steel bolts (rupture resistance 800N/mm, limit of elasticity 640N/mm)
- A screw/nut coefficient of friction of 0.12

**Bellows are delivered with limit bolts set at the maximum length. Limit bolts must not be removed otherwise bellows could exceed the maximum length.**

**All installation and operating instructions specified in the instructions supplied with the products.**

# BELLOW FLANGES

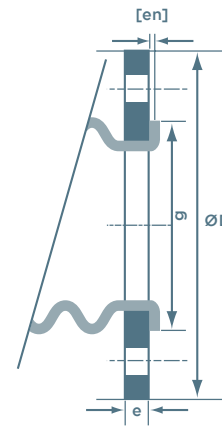
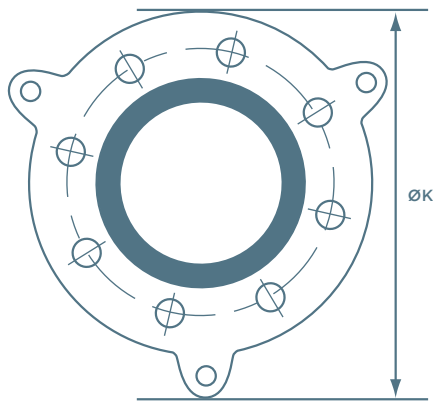

BELLOWS TYPES 207 - 227								DRILLING (*)	
DN (mm)	DN (inches)	D (mm)	K (mm)	g (mm)	e (mm)	[en] (mm)	Drilling orientation	PN 10	ASA 150 Lbs
20	¾"	105	155	43	10	2,5	X	4x dia 14 out of 75 mm	4x dia 16 out of 69 mm
25	1"	115	160	52	12	2,5	X	4x dia 14 out of 85 mm	4x dia 16 out of 79,4 mm
32	1¼"	140	190	62	12	3	X	4x dia 18 out of 100 mm	4x dia 16 out of 88,9 mm
40	1½"	150	200	70	13	3	X	4x dia 18 out of 110 mm	4x dia 16 out of 98,4 mm
50	2"	165	220	90	16	3,5	X	4x dia 18 out of 125 mm	4x dia 20 out of 120,6 mm
65	2½"	185	240	108	16	3	X	4x dia 18 out of 145 mm	4x dia 20 out of 139,7 mm
80	3"	200	255	122	16	3	H	8x dia 18 out of 160 mm	4x dia 20 out of 152,4 mm
100	4"	230	290	148	16	3,5	H	8x dia 18 out of 180 mm	8x dia 20 sur 190,5 mm
125	5"	255	315	174	18	4	H	8x dia 18 out of 210 mm	8x dia 23 out of 215,9 mm
150	6"	285	345	200	18	4	H	8x dia 22 out of 240 mm	8x dia 23 out of 241,3 mm
200	8"	345	405	256	20	4	H	8x dia 22 out of 295 mm	8x dia 23 out of 298,4 mm
250	10"	410	470	303	25	4	H	12x dia 22 out of 350mm	12x dia 26 out of 361,9 mm
300	12"	485	545	353	25	4	H	12x dia 22 out of 400 mm	12x dia 26 out of 431,8 mm
350	14"	535	595	402	27	4,5	H	16x dia 22 out of 460 mm	12x dia 29 out of 476,2 mm
400	16"	600	660	453	26	4	H	16x dia 26 out of 515 mm	16x dia 29 out of 539,8 mm
450	18"	640	695	513	28	3,5	H	20x dia 26 out of 565 mm	16x dia 32 out of 577,8 mm
500	20"	700	760	564	30	4	H	20x dia 26 out of 620 mm	20x dia 32 out of 635 mm
600	24"	818	885	658	32	4	H	20x dia 30 out of 725 mm	20x dia 35 out of 749,3 mm



(\*) Specific drilling upon request

- "X" stands for drillings "on axis / out of axis"
- "H" stands for drillings "on axis / on axis"
- [en] is the nominal thickness of PTFE liners



# COMPENSATOR FLANGES

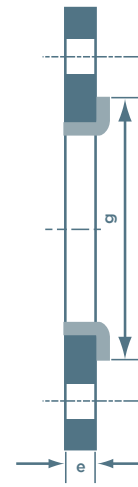
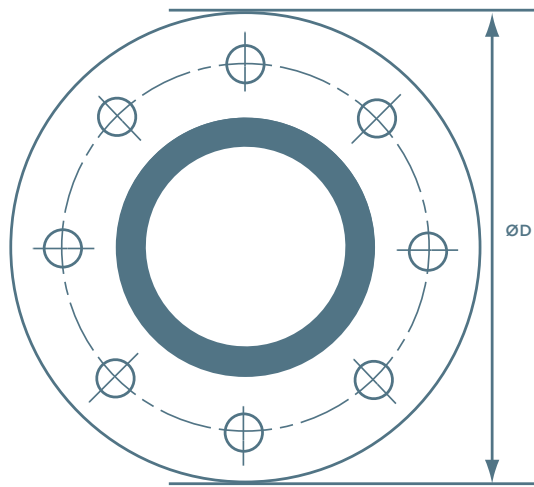

COMMON CHARACTERISTICS				DRILLING PN10		DRILLING ANSI 150	
DN (mm)	DN (inches)	en (mm)	g (mm)	D (mm)	e (mm)	D (mm)	e (mm)
50	2"	3,5	98	165	18	152,4	22
65	2½"	3	118	185	18	177,8	24
80	3"	9	127	200	22	190,5	24
100	4"	3,5	158	230	22	228,6	24
125	5"	4	188	255	24	254	24
150	6"	4	212	285	24	279,4	25
200	8"	4	268	345	24	342,9	29
250	10"	4	320	410	26	106,4	30
300	12"	4	370	485	26	482,6	32
350	14"	4,5	430	535	28	533,4	35
400	16"	4,5	480	600	32	596,9	36,5
450	18"	3,5	532	640	38	635	40
500	20"	4	585	700	38	698,5	43
600	24"	4	685	815	40	812,8	48

# STANDARD BELLOWS TYPE 207

## RANGES G (STANDARD) AND V (VACUUM)

### CHARACTERISTICS



- L** is the dimension to be obtained at Installation (neutral length)
- F<sub>x</sub>** and **F<sub>y</sub>** are the forces of compression and offset in daN for an axial movement  $\Delta x = 1$  mm or a misalignment  $\Delta y = 1$  mm
- C2** : x on the column must be filled in according to your specifications: 1 = PN10, 2 = 150 lbs, etc.
- C3** : - (here in standard). The vacuum option V is only available for 3 convolutions bellows

DN mm	DN inches	Nber Convo- lutions	L mm	$\Delta x$ mm	$\Delta y$ mm	F <sub>x</sub> DaN/ mm	F <sub>y</sub> DaN/ mm	Weight kg	AVAILABILITY		REFERENCES									
									Range G	Range V	C1	C2	C3	C4	C5	C6	C7	C8	C9	C10
20	¾"	3	50	10	8	4,5	2	2,5	✓		S	x	-	-	2	0	7	-	3	J
25	1"	3	50	12	10	4,5	2	2,5	✓		S	x	-	-	2	0	7	-	3	K
		5	75	20	15	4	1,5	2,8	✓		S	x	-	-	2	0	7	-	5	K
32	1¼"	3	50	12	12	5	2,5	3	✓		S	x	-	-	2	0	7	-	3	L
		5	75	20	18	4	2	3,5	✓		S	x	-	-	2	0	7	-	5	L
40	1½"	3	50	12	15	5	2,8	4	✓		S	x	-	-	2	0	7	-	3	M
		5	75	20	20	4	2	4,5	✓		S	x	-	-	2	0	7	-	5	M
50	2"	3	75	15	15	5	4,5	6	✓		S	x	-	-	2	0	7	-	3	N
		5	100	25	20	4	3,5	6,5	✓		S	x	-	-	2	0	7	-	5	N
65	2½"	3	75	22	17	4	5	7	✓	✓	S	x	-	-	2	0	7	-	3	O
		5	100	35	30	3,5	4	7,5	✓		S	x	-	-	2	0	7	-	5	O
80	3"	3	100	25	17	4	6	8	✓	✓	S	x	-	-	2	0	7	-	3	P
		5	125	40	30	3,5	4,5	9	✓		S	x	-	-	2	0	7	-	5	P
100	4"	3	100	25	17	5	9	10	✓	✓	S	x	-	-	2	0	7	-	3	Q
		5	150	40	30	3,5	6	11	✓		S	x	-	-	2	0	7	-	5	Q
125	5"	3	125	28	18	6	11	12	✓	✓	S	x	-	-	2	0	7	-	3	R
		5	175	45	32	4	8	13	✓		S	x	-	-	2	0	7	-	5	R
150	6"	3	150	28	18	10	15	15	✓	✓	S	x	-	-	2	0	7	-	3	S
		5	225	45	32	8	12	17	✓		S	x	-	-	2	0	7	-	5	S
200	8"	3	150	28	20	15	18	20	✓	✓	S	x	-	-	2	0	7	-	3	T
		5	225	45	32	10	15	22	✓		S	x	-	-	2	0	7	-	5	T
250	10"	3	150	28	10	15	20	35	✓	✓	S	x	-	-	2	0	7	-	3	U
		5	225	45	15	10	17	37	✓		S	x	-	-	2	0	7	-	5	U
300	12"	3	150	30	8	15	20	48	✓	✓	S	x	-	-	2	0	7	-	3	V
		5	225	50	10	12	17	50	✓		S	x	-	-	2	0	7	-	5	V
350	14"	3	150	30	6	20	27	57	✓	✓	S	x	-	-	2	0	7	-	3	W
		5	225	50	8	16	23	59	✓		S	x	-	-	2	0	7	-	5	W
400	16"	3	150	30	6	20	27	70	✓	✓	S	x	-	-	2	0	7	-	3	X
		5	225	50	8	16	23	72	✓		S	x	-	-	2	0	7	-	5	X
450	18"	3	150	30	5	25	29	78	✓	✓	S	x	-	-	2	0	7	-	3	Y
		5	225	50	7	20	24	80	✓		S	x	-	-	2	0	7	-	5	Y
500	20"	3	150	30	5	30	35	86	✓	✓	S	x	-	-	2	0	7	-	3	Z
		5	225	50	7	25	30	89	✓		S	x	-	-	2	0	7	-	5	Z
600	24"	3	175	30	4	30	35	125	✓	✓	S	x	-	-	2	0	7	-	3	B
		5	250	50	6	25	30	130	✓		S	x	-	-	2	0	7	-	5	B
750	30	3	190	30	4	30	35	200	✓	✓	S	x	-	-	2	0	7	-	3	ZE
900	36	3	215	30	3	30	35	300	✓	✓	S	x	-	-	2	0	7	-	3	ZH
1050	42	3	240	30	2	30	35	730	✓	✓	S	x	-	-	2	0	7	-	3	ZK

## RANGE

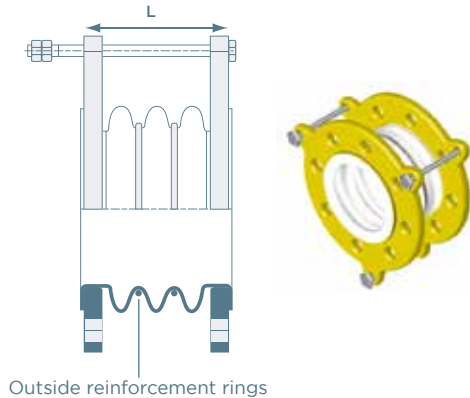

Outside reinforcement rings

Bellow Standard Range G207  
3 and 5 convolutions

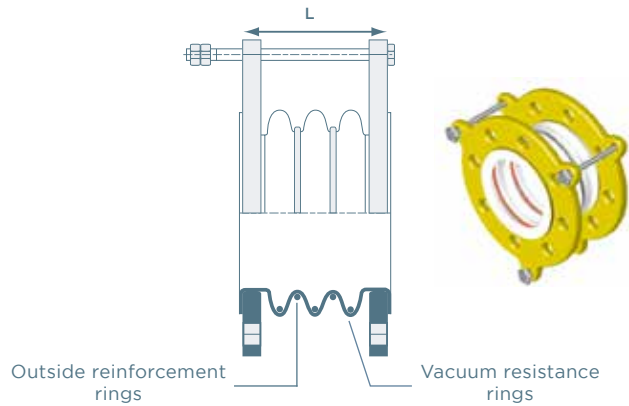

Outside reinforcement rings

Vacuum resistance rings

Bellow Range Vacuum V207  
Available only with 3 convolutions

## THE PERFORMANCE CURVES

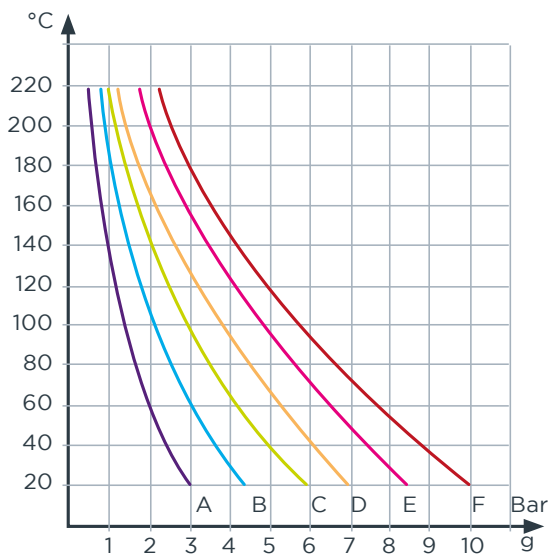

PRESSURE RESISTANCE  
Ranges G (standard) and V (Vacuum) - 3 convolutions

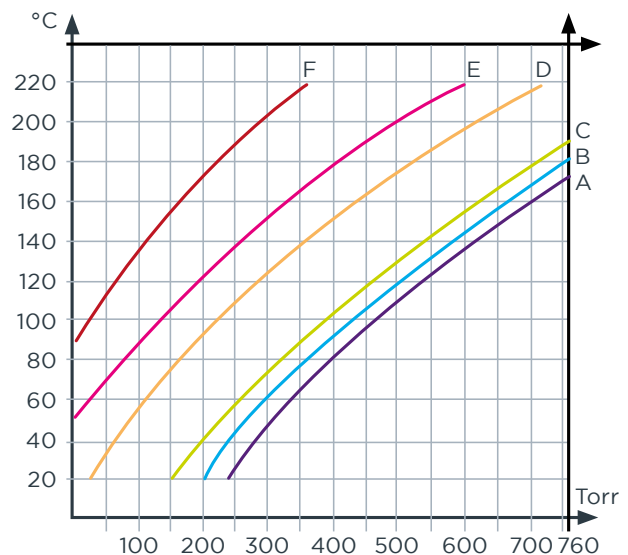

VACUUM RESISTANCE  
Range G (standard)



- For G 5 convolutions standard bellow, the values of vacuum and pressure resistance must be multiplied by 0.5
- The vacuum resistance of G207 bellows from DN20 to DN50 together with V207 bellows is 2 Torr up to 180°C
- DN750, 900 and 1050 are available upon request

For operation in corrosive environment, MERSEN offers serie 204 bellows with nickel alloys C 276 rings. The characteristics and sizes of the type 204 bellows are identical to those of type 207

CURVES	DN (mm)
A	500 & 600
B	400 & 450
C	300 & 350
D	200 & 250
E	100 & 150
F	25 à 80

DN 750 - 900 - 1050 PRESSURE RESISTANCE  
(RANGE G & V) - 3 WAVES

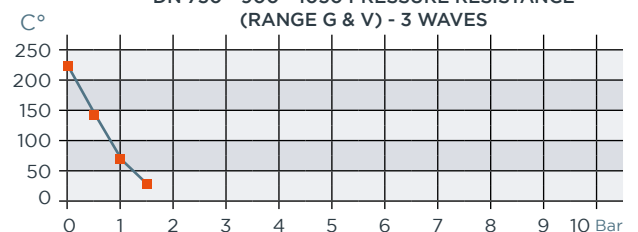

# REINFORCED BELLOWS TYPE 227

## RANGE G (STANDARD) AND V (VACUUM)

### CHARACTERISTICS

DN mm	DN inches	Nber Convo- lutions	L mm	$\Delta x$ mm	$\Delta y$ mm	Fx DaN/ mm	Fy DaN/ mm	Weight kg	AVAILABILITY		REFERENCES									
									Range G	Range V	C1	C2	C3	C4	C5	C6	C7	C8	C9	C10
25	1"	3	50	7	4	4,5	2	2,5	✓		S	x	-	-	2	2	7	-	3	K
32	1¼"	3	50	7	4	5	2,5	3	✓		S	x	-	-	2	2	7	-	3	L
40	1½"	3	50	7	5	5	2,8	4	✓		S	x	-	-	2	2	7	-	3	M
50	2"	3	75	8	5	5	4,5	6,5	✓		S	x	-	-	2	2	7	-	3	N
65	2½"	3	75	10	5	4	5	7,5	✓	✓	S	x	-	-	2	2	7	-	3	O
80	3"	3	100	15	8	4	6	8,5	✓	✓	S	x	-	-	2	2	7	-	3	P
100	4"	3	100	15	8	5	9	11	✓	✓	S	x	-	-	2	2	7	-	3	Q
125	5"	3	125	20	10	6	11	13	✓	✓	S	x	-	-	2	2	7	-	3	R
150	6"	3	150	28	10	10	15	16	✓	✓	S	x	-	-	2	2	7	-	3	S
200	8"	3	150	28	10	15	18	21	✓	✓	S	x	-	-	2	2	7	-	3	T
250	10"	3	150	28	10	15	20	36	✓	✓	S	x	-	-	2	2	7	-	3	U
300	12"	3	150	30	8	15	20	49	✓	✓	S	x	-	-	2	2	7	-	3	V
350	14"	3	150	30	6	20	27	58	✓	✓	S	x	-	-	2	2	7	-	3	W
400	16"	3	150	30	6	20	27	72	✓	✓	S	x	-	-	2	2	7	-	3	X
450	18"	3	150	30	5	25	29	80	✓	✓	S	x	-	-	2	2	7	-	3	Y
500	20"	3	150	20	5	30	35	89	✓	✓	S	x	-	-	2	2	7	-	3	Z
600	24"	3	175	20	4	30	35	130	✓	✓	S	x	-	-	2	2	7	-	3	B



For operation in corrosive environment, MERSEN offers serie 224 bellows with nickel alloys C 276 and MONEL 400 shells  
The characteristics and the dimensions of type 224 bellows are identical to those of 227



- L** is the dimension to be obtained during installation (neutral length)
- Fx** and **Fy** are the forces of compression and offset in daN for an axial movement  $\Delta x = 1$  mm or a misalignment  $\Delta y = 1$  mm
- C2** : x on the column must be filled in according to your specifications : **1** = PN10, **2** = 150 lbs, etc.
- C3** : - (here in standard). The vacuum option V is only available for 3 convolutions bellows

## RANGE

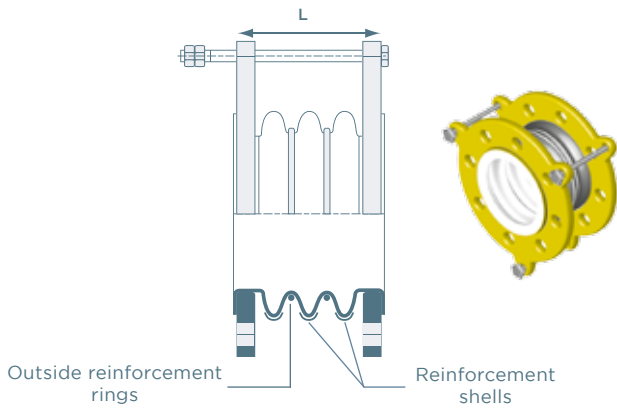

BELLOW STANDARD RANGE G227  
3 convolutions only

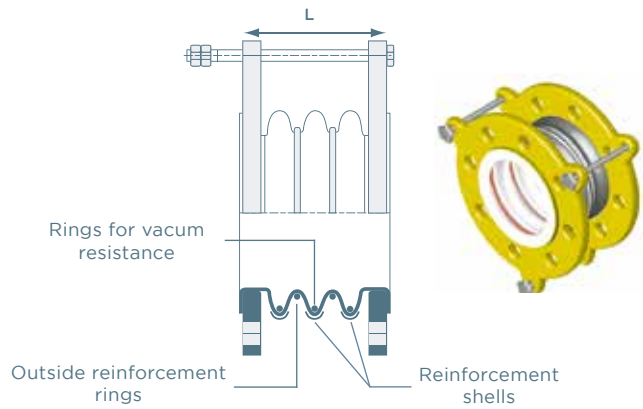

BELLOW RANGE VACUUM V227  
3 convolutions only

## PERFORMANCE CURVES

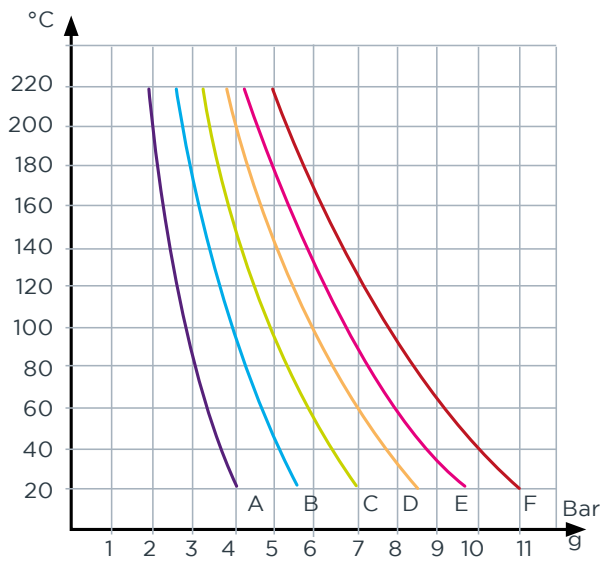

PRESSURE RESISTANCE  
Range G (standard) and V (Vacuum) - 3 convolutions

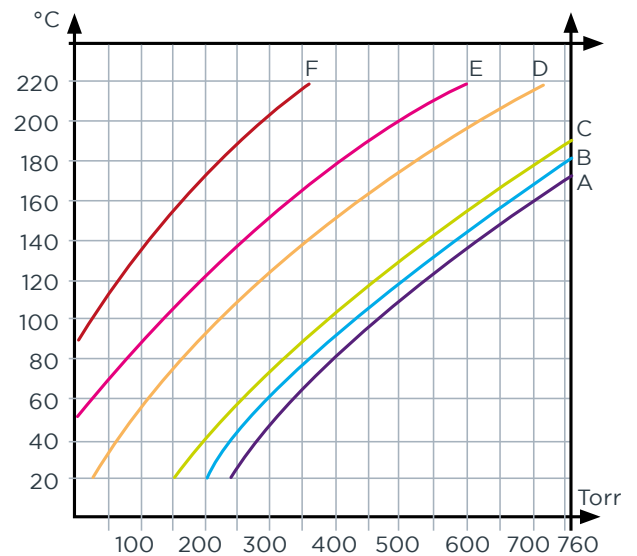

VACUUM RESISTANCE  
Range G (standard)



- G Bellows from DN25 to DN50 withstand vacuum resistance of 2 Torr at 180°C
- The vacuum resistance of V227 bellows is 2 Torr up to 180°C

CURVES	DN (mm)
A	500 & 600
B	400 & 450
C	300 & 350
D	200 & 250
E	100 & 150
F	25 à 80

# COMPENSATORS TYPE G 283

## CHARACTERISTICS

In contrast to bellows, MERSEN compensators are not equipped with limit bolts.

DN mm	DN inches	L mm	± Δ x mm	± Δ y mm	Fx DaN/ mm	Fy DaN/ mm	Weight kg	REFERENCES									
								C1	C2	C3	C4	C5	C6	C7	C8	C9	C10
50	2"	150	3.5	2.5	14.2	9.6	5,5	S	x	-	-	2	8	3	-	-	N
80	3"	150	4	2	22.8	26	7,5	S	x	-	-	2	8	3	-	-	P
100	4"	150	5	2	48.1	51.9	8,5	S	x	-	-	2	8	3	-	-	Q
125	5"	150	5	2	137.2	361.3	11	S	x	-	-	2	8	3	-	-	R
150	6"	195	11	4	48.2	122.8	13	S	x	-	-	2	8	3	-	-	S
200	8"	245	14	4.5	77.4	126.4	20	S	x	-	-	2	8	3	-	-	T
250	10"	245	17	6	55.1	142.1	27	S	x	-	-	2	8	3	-	-	U
300	12"	400	24	13	81.1	68.9	41	S	x	-	-	2	8	3	-	-	V
350	14"	400	39	19	52.7	60.3	55	S	x	-	-	2	8	3	-	-	W
400	16"	400	42	18	49.2	73.7	75	S	x	-	-	2	8	3	-	-	X
450	18"	400	36	14	50	110.6	80	S	x	-	-	2	8	3	-	-	Y
500	20"	400	36	13	48.30	129.9	100	S	x	-	-	2	8	3	-	-	Z
600	24"	400	36	11	51.8	198.6	120	S	x	-	-	2	8	3	-	-	B



**C2** : x on the column must be filled in according to your specifications: 1 = PN10, 2 = 150 lbs, etc..

The specification or data herein contained are only given for indication, without any undertakings whatsoever. Their publication does not suggest the matter is free of any rights whatsoever. Furthermore, due to constant evolution of techniques and norms, we reserve the right to modify, at any time, the characteristics and specifications contained in this document. MERSEN refuses all and any responsibility concerning their use whatever the purpose or application. Any copy, reproduction or information herein contained, in whole or in part, made without MERSEN written consent, is forbidden according to the laws of France and particularly the law nr. 92-597 of July 1st 1992 relating to the copyright.

## RANGE

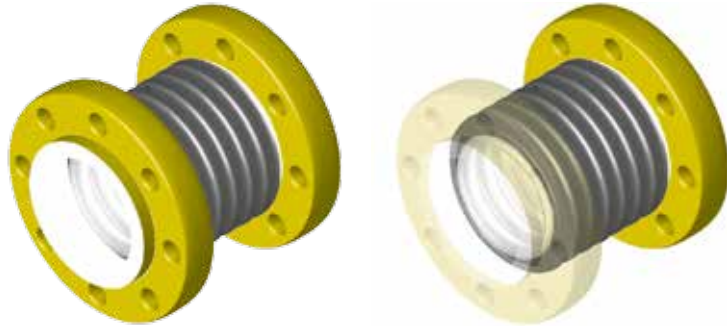
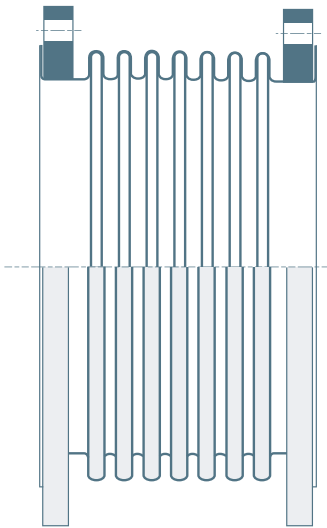

COMPENSATOR G283

## PERFORMANCE CURVES

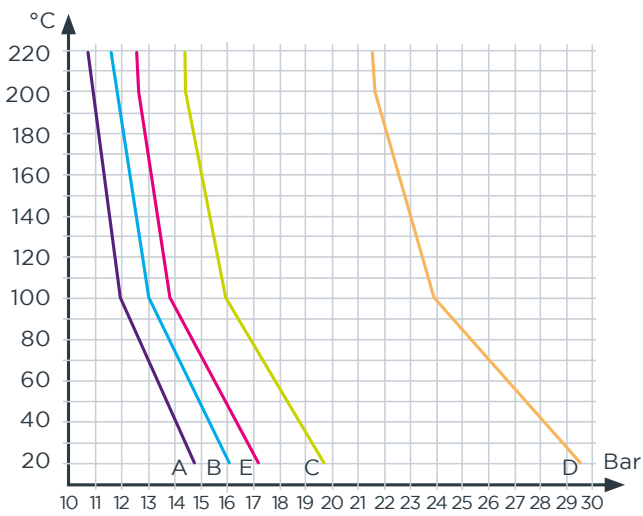

PRESSURE RESISTANCE

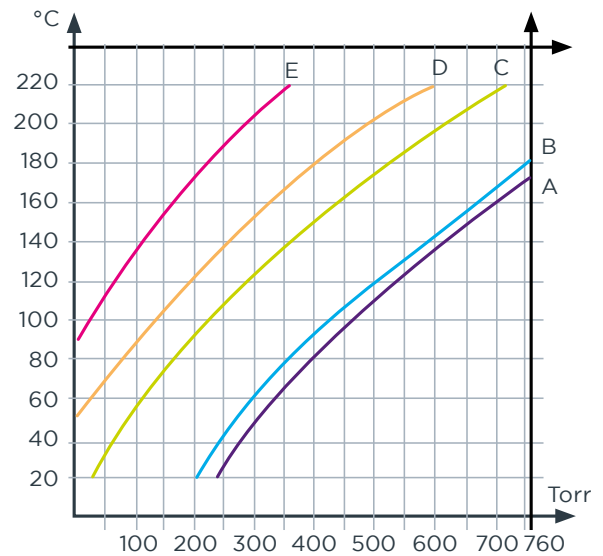

VACUUM RESISTANCE



Warning: Design pressures of flanges must be lower than operating pressures of membranes as shown by the performance curves. The maximum operating pressures of compensators are limited to their flanges pressures design.

CURVES	DN (mm)
A	500 & 600
B	300 & 450
C	200 & 250
D	100 & 150
E	50 & 80





GLOBAL EXPERT IN ELECTRICAL  
POWER AND ADVANCED MATERIALS

#### EUROPE

##### FRANCE

Mersen France Py S.A.S.  
Tel : +33 (0)3 83 81 60 81  
info.pagny@mersen.com

##### GERMANY

Mersen Deutschland  
Linsengericht GmbH  
Tel : +49 (0) 6051 71 037  
info.lsg@mersen.com

##### ITALIA

Mersen Italia S.p.A.  
Tel : +39 02 82 681 31  
ce.italia@mersen.com

##### SPAIN

Mersen Iberica fma, S.A.  
Tel : +34 93 685 7800  
olga.martinez@mersen.com

##### THE NETHERLANDS

Mersen Benelux B.V.  
Tel : +31(0)10 298 30 30  
contact.schiedam@mersen.com

##### UNITED KINGDOM

Mersen UK Teesside Ltd.  
Tel : +44 (0)1642 790100  
victoria.stephenson@mersen.com

#### RUSSIA & EASTERN EUROPE

Tel : +7 (964) 768 14 05  
jean-pierre.lemoine@mersen.com

##### TURKEY

Mersen Istanbul San. Ür. A. Ş.  
Tel : +90 262 751 0262  
sales.istanbul@mersen.com

#### ASIA

##### CHINA

Mersen XIANDA  
Tel : +86 21 5752 7777  
info.xianda@mersen.com

##### INDIA

Mersen India  
Tel : +91 9845331292  
/+91 9840078844  
sales.ce.india@mersen.com

##### JAPAN

MERSEN FMA JAPAN K.K.  
Tel : +81 (3) 5368-3250  
hajime.kagaya@mersen.com

##### KOREA

Mersen Korea Co., Ltd.  
Tel : +82 (0)2 598 0071  
sales.korea@mersen.com

##### SOUTH EAST ASIA

Tel : +91 9500041487  
srikrishna.natesan@mersen.com

#### NORTH AMERICA

##### USA

Mersen USA Salem  
Tel : +1 540 389-7535  
joel.svec@mersen.com

##### Mersen USA Gonzales

Tel : +1 225 647-6752  
dsholar@mersen.com

#### AFRICA

##### MOROCCO

Mersen Maroc S.A.R.L.  
Tel : + 212 (0) 523 38 30 12  
contact.maroc@mersen.com

##### SOUTH AFRICA

Mersen South Africa, (Pty) Ltd.  
Tel : +27 011 474 0000  
keith.pillay@mersen.com

#### MIDDLE EAST & AFRICA

Tel : +33 (0)3 83 81 60 81  
Info.pagny@mersen.com

#### SOUTH AMERICA

##### ARGENTINA

Mersen Argentina, S.A.  
Tel : +54 11 49 18 21 21  
infos.latam@mersen.com

##### BRAZIL

Mersen Do Brasil, Ltda.  
Tel : +55 (11) 4529 1160  
jorge.lopes@mersen.com

##### CHILE

Mersen Chile  
Tel : +56 22 621 5680  
ventas@mersen.cl

##### COLOMBIA

Mersen Colombia  
Tel : +57 (1) 3684588  
ace.latam@mersen.com

##### MEXICO & LATIN AMERICA

Mersen Mexico Monterrey  
Tel : +52 (81) 8127 2812  
ace.latam@mersen.com



WWW.MERSEN.COM